

□ · BASF

We create chemistry

EXACTUS[®] HELIOS USER GUIDE

INDUSTRIAL Handheld Pyrometer

v1.3

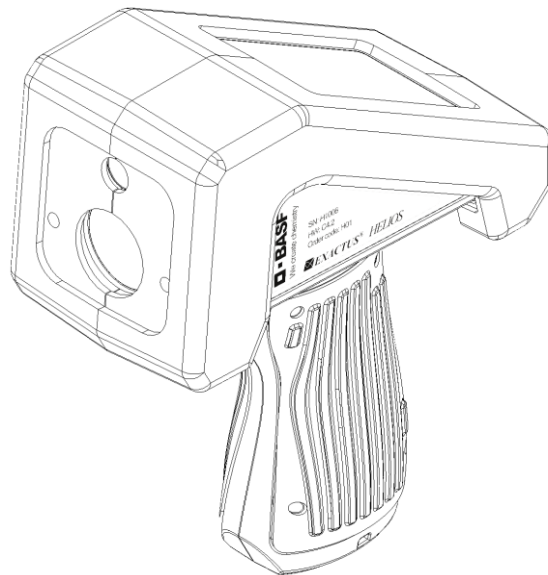

1 Contact Information

Technical

4099 SE International Way, Suite 203
Portland, OR 97222
Phone: (503) 794-4073
Fax: (503) 794-5591

Purchasing

46820 Fremont Blvd.
Fremont, CA 94538
Phone: (510) 490-2150
Fax: (510) 252-1871

EXACTUS[®] is a registered trademarks of BASF. The data contained in this publication are based on our current knowledge and experience. In view of the many factors that may affect processing and application of our product, these data do not relieve processors from carrying out their own investigations and tests; neither do these data imply any guarantee of certain properties, nor the suitability of the product for a specific purpose. Any descriptions, drawings, photographs, data, proportions, weights, etc. given herein may change without prior information and do not constitute the agreed contractual quality of the product. It is the responsibility of the recipient of our products to ensure that any proprietary rights and existing laws and legislation are observed.

Although all statements and information in this publication are believed to be accurate and reliable, they are presented gratis and for guidance only, and risks and liability for results obtained by use of the products or application of the suggestions described are assumed by the user. NO WARRANTIES OF ANY KIND, EITHER EXPRESS OR IMPLIED, INCLUDING WARRANTIES OF MERCHANTABILITY OR FITNESS FOR A PARTICULAR PURPOSE, ARE MADE REGARDING PRODUCTS DESCRIBED OR DESIGNS, DATA OR INFORMATION SET FORTH. Statements or suggestions concerning possible use of the products are made without representation or warranty that any such use is free of patent infringement and are not recommendations to infringe any patent. The user should not assume that toxicity data and safety measures are indicated or that other measures may not be required. ©2025 BASF

Contents

1	Contact Information	2
2	Specifications	4
3	Product Overview	4
3.1	Description and Intended Use	4
3.2	Certifications and Approvals	4
3.3	Identification	4
3.4	Powering On the Device	5
3.5	Powering Off the Device	5
3.6	Device overview	5
4	Optics and Sighting	6
4.1	Aiming	7
5	Screens and settings	9
5.1	Menu Tree and Navigation	9
5.2	Main Screen	10
5.3	Battery Icon Status	11
5.4	Operation Modes	12
5.5	Setting Emissivity	13
5.6	Taking measurements	14
5.7	Reviewing recorded temperatures	14
5.8	Settings	18
6	Replacing the battery	22
7	Troubleshooting	23
8	Warnings	23
8.1	Repair, Service, and Returns	23
8.2	Disposal	23

2 Specifications

Range	400–2000°C / 752–3632°F
Modes	Instant, Average, Minimum, Maximum
Storage	32gb, approximately 300K measurements
Optics	Fixed focus
Target size	20mm at 3m
Spectral response	1um
Emissivity adjustment	0.01 – 1.10
Drift	Max 0.10°C per year (maximum)
Accuracy	± 1.5°C or 0.2 % of measured temperature
Weight	600g (1.3Lb)
Operating range	10-60°C
Sealing	IP61
Power source	Li-ion 2 cell Series Parallel (1S2P) 3.7V 5200mAH 19.2Wh
Laser	Class II, < 1mW
Camera	2MP Global shutter

3 Product Overview

3.1 Description and Intended Use

The **EXACTUS[®] HELIOS** is a portable temperature measurement device for use in industrial environments. It records temperatures and images which can then be accessed via USB.

3.2 Certifications and Approvals



3.3 Identification

The **EXACTUS[®] HELIOS** features a nameplate.

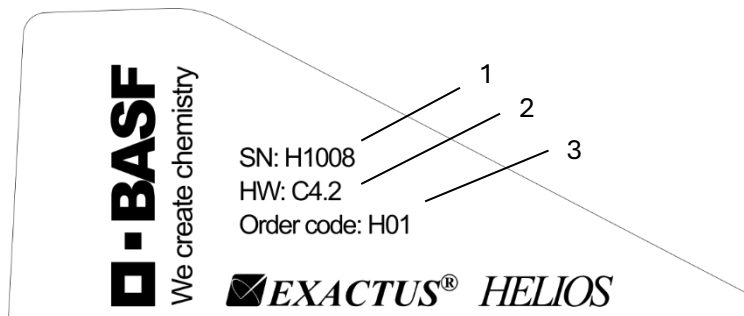

Figure 1 - Example label

1. SERIAL NUMBER
2. DEVICE VERSION
3. ORDER CODE

3.4 Powering On the Device

To turn on the *EXACTUS*® HELIOS:

1. **Press and hold the power button to power on**
 - Press and hold the power button for **3–5 seconds**.
 - The **green targeting lasers** and the **screen backlight** will turn on, indicating the startup sequence has begun.
2. **Release immediately**
 - Release the power button as soon as the screen lights up.
 - **Caution:** Holding the button too long will trigger an immediate shutdown, a safety feature designed to prevent accidental battery drain.
3. **Wait for the main screen**
 - The device will complete its startup routine and automatically transition to the **measurement screen**, ready for use.

Note: If the device does not power on, check the battery charge level and recharge if necessary (see Section 5.3.1 How to Charge).

3.5 Powering Off the Device

To turn off the *EXACTUS*® HELIOS:

- Press and hold the **power button** for **3–5 seconds** until the **screen goes black**.
- Release the button immediately once the screen turns off. The device is now powered down.

Note: In addition to manual shutdown, the device can be configured to turn off automatically using the **Power Management Settings** (see Section 5.8.5).

3.6 Device overview

The *EXACTUS*® *HELIOS* is a robust and lightweight handheld device with a 4” touchscreen. It has a single physical button on the back side for powering on and off. A USB-C port on the bottom for charging, retrieval of saved measurements, and firmware updates. A trigger on the handle allows the user to record measurements.

3.6.1 Feature callout

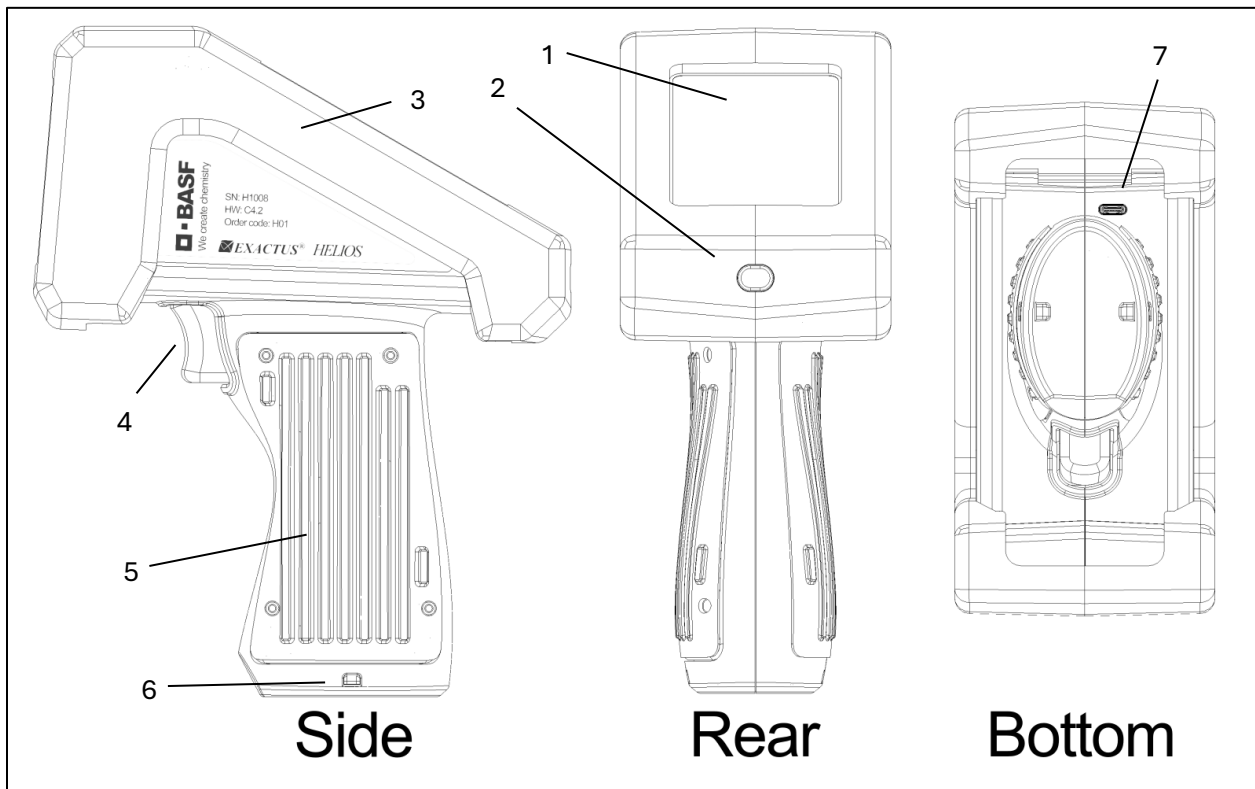

Figure 2- Device overview

1. 4" TOUCH SCREEN
2. POWER BUTTON
3. Protective cover
4. TRIGGER
5. BATTERY COVER
6. LANYARD LOOP
7. USB-C PORT/CHARGING PORT

4 Optics and Sighting

The **EXACTUS[®] HELIOS** provides target vision with a camera located 2 cm above the optical axis of the pyrometer. Green targeting lasers are positioned 2 cm to the left and right. All four optical axes are aligned during manufacturing to be parallel with one another. The focus of the camera and pyrometer are fixed.

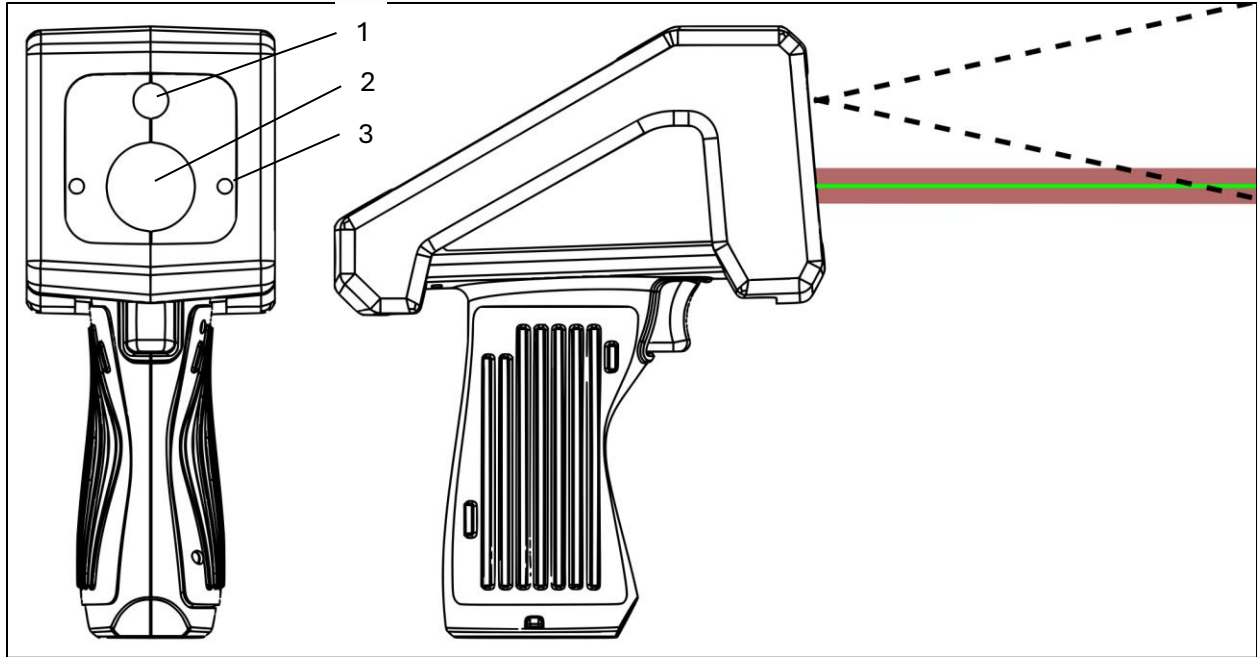

Figure 3 - Optical overview

1. CAMERA
2. PYROMETER
3. Green dot laser

4.1 Spot size

target distance		collection area	
feet	meters	mm	in
32.8	10	140	5.5
16.4	5	60	2.4
9.8	3	30	1.2
6.6	2	20	0.8
3.3	1	20	0.8

4.2 Aiming

Since the pyrometer and the camera are on different optical axes, the area on the screen where the pyrometer is collecting light depends on the distance. **EXACTUS® HELIOS** has a specially designed reticle to assist with properly aiming the device.

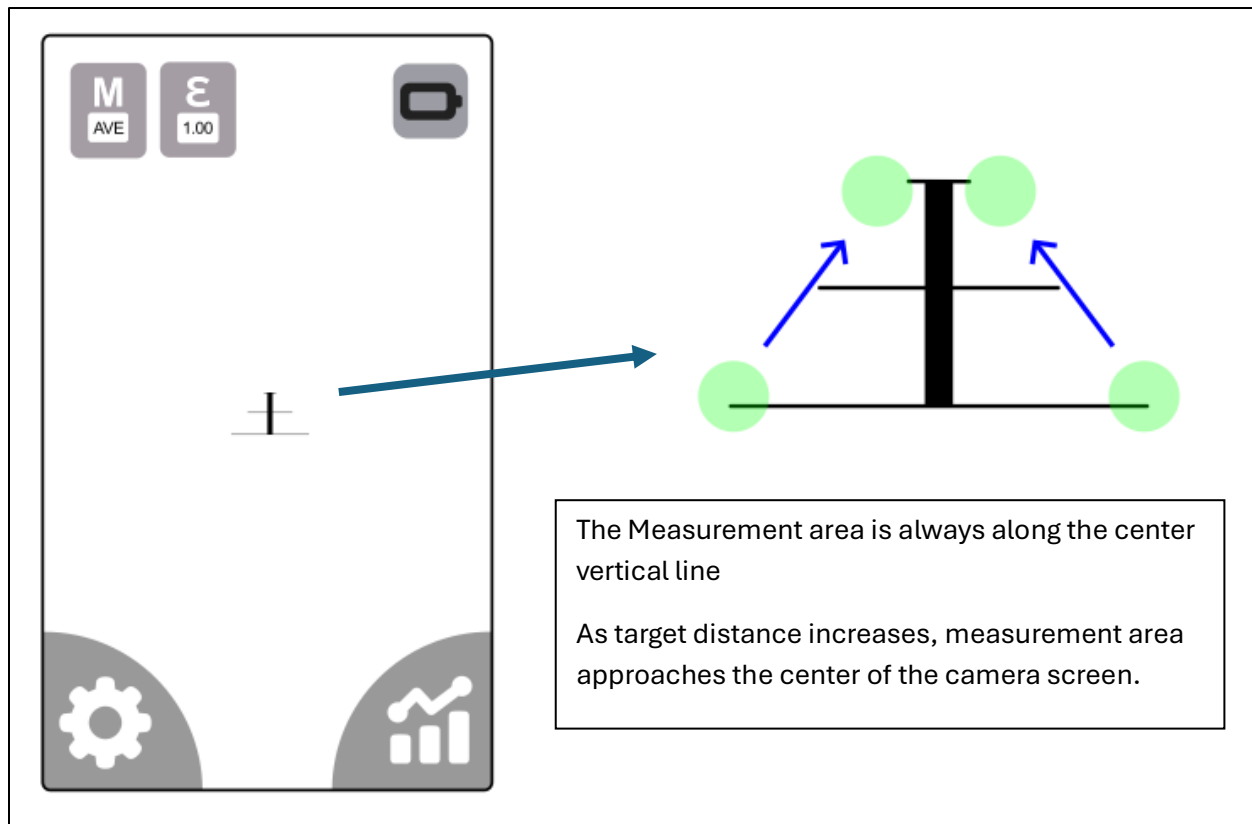

Figure 4 - Measurement Area Alignment

The reticle is designed to show how the measurement position changes with distance. The horizontal lines show where the targeting lasers will appear at different distances.

The bottom line represents a distance of about 1 meter. The top line represents about 3.5 meters.

At any distance, the measurement point is where the line between the two laser dots crosses the center vertical line.

As you aim from near to far, the laser dots move upward and get closer together on the screen.

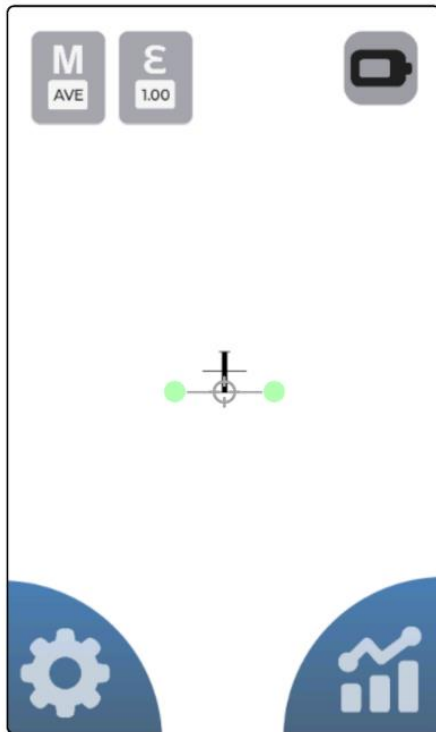

Measurement distance: ~1 m

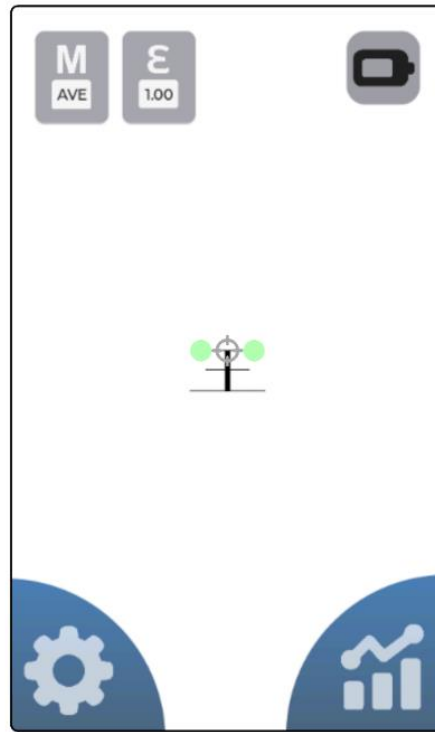

Measurement distance: ~3.5 m

Figure 5 - Laser Spot Position at Varying Distances

5 Screens and settings





The **EXACTUS[®] HELIOS** uses a 4" touchscreen interface for all operations. The following screens are available:

5.1 Menu Tree and Navigation

(To be updated once the UI screens are finalized.)

5.2 Main Screen

The main screen appears after startup and displays:

- 1. LIVE TEMPERATURE READING
- 2. RETICLE OVERLAY
- 3. CAMERA IMAGE
- 4. MODE INDICATOR  (INSTANT, AVERAGE, MIN, MAX)
- 5. EMISSIVITY INDICATOR 
- 6. ACCESS ICONS FOR RECORDS 
- 7. ACCESS ICONS FOR SETTINGS 

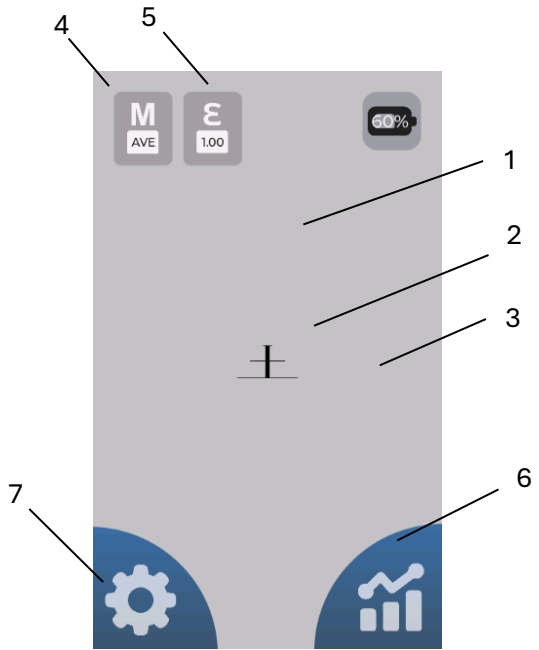

Figure 6 - Main screen with live image and reticle

5.3 Battery Icon Status

The battery icon on the main screen indicates the current power level and charging status of the device.



100% – The battery is fully charged.



Charging – The device is connected to external power and is currently charging.



0% – The battery is fully depleted. The device will shut down automatically if not connected to external power.



20% – The battery charge is low ($\leq 20\%$). The icon changes to **red** to alert the user that the device should be recharged soon.

The **battery percentage (%) is displayed inside the icon**. This provides the user with both a quick visual indicator and detailed information for planning.

Note: When the battery icon turns **red**, connect the device to a power source to avoid unexpected shutdown.

5.3.1 How to Charge

To charge the EXACTUS® HELIOS:

- 1. Power connection**
 - Locate the **USB-C port** at the bottom of the device.
 - Connect the supplied **USB-C cable** to the port.
 - Plug the other end into a certified USB power adapter or computer port.
- 2. Charging status**
 - When charging, the **battery icon** on the main screen shows a charging symbol.
 - The **exact battery percentage** will be displayed inside the icon.
- 3. Completion**
 - A **100% battery icon** indicates the device is fully charged.
 - The device may remain connected to power without risk of overcharging.

LED indicator status

- A **red LED (steady)** indicates the battery is charged.
- A **flashing LED** indicates that the battery is actively charging.

5.4 Operation Modes

The *EXACTUS*[®] *HELIOS* supports four measurement modes. Modes can be selected from the Mode screen.

Note: While the trigger is held, the device collects a group of temperature readings. Each mode displays different results based on this data group.

1. **Instantaneous**
Displays the current temperature reading for each data group recorded while the trigger is held. This is the default measurement mode.
2. **Average**
Displays the average temperature calculated from each data group recorded while the trigger is held.
3. **Minimum**
Displays the minimum temperature recorded within each data group while the trigger is held.
4. **Maximum**
Displays the maximum temperature recorded within each data group while the trigger is held.

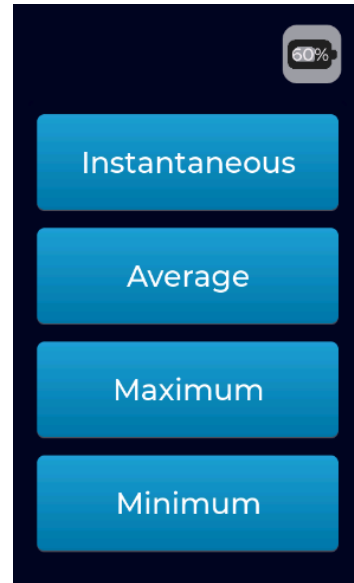

Figure 7 – Operating Mode Screen

5.5 Setting Emissivity

The emissivity setting adjusts how the device interprets thermal radiation from different materials.

To change the emissivity value:

- Use the slider or plus/minus buttons to set a value between **0.01** and **1.20**.
- Tap **Reset to 1.00** to return to the default value.
- Tap **Save** to confirm the setting.

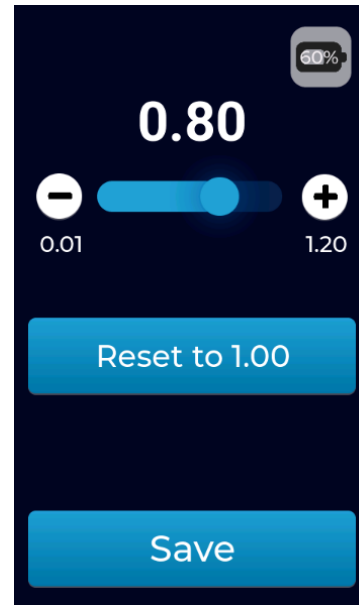

Figure 8 – Emissivity Adjustment Screen

5.6 Taking measurements

To perform a temperature measurement, follow the steps below:

5.6.1 Aim at the target

Point the device toward the desired measurement area. The actual measurement point is located at the intersection of the vertical line and the line between the laser dots.

Tip: For best accuracy, avoid shiny or reflective surfaces that may affect the reading.

5.6.2 Pull the trigger

The trigger controls both aiming and data capture:

- **Partially pull** the trigger to activate aiming mode.
The device will display a live temperature reading on screen without storing any data. This allows for fine adjustment before measurement.
- **Fully pull** the trigger to take and store a measurement.
The device records measurements at a rate of approximately **10–20 readings per second**, starting from the moment the trigger is pulled. The HELIOS can currently store up to **300,000 measurements** in memory.

If the screen is dimmed or off due to inactivity, pulling the trigger will also wake the screen.

Tip: Hold the trigger steadily during aiming and measuring. Sudden movement may cause inaccurate readings.

5.7 Reviewing recorded temperatures

Saved temperature records can be accessed and reviewed directly on the device. Data includes temperature, time, and captured image, and can be filtered by date.

5.7.1 Accessing the Records Screen

Tap the Record icon  on the main screen to open the Records screen. Records are grouped by date; tap a date to view entries for that day. Each entry displays:

- Measured temperature
- Time of capture
- Unit (°C or °F)
- A bar showing minimum, average, and maximum range for the sample



Figure 9 – Records Review Screen

5.7.2 Viewing Record Details

Tap any individual record to open the **Datapoints** screen. This screen displays:

- Timestamp
- Emissivity value used
- Graph of recorded temperature variation
- Captured image

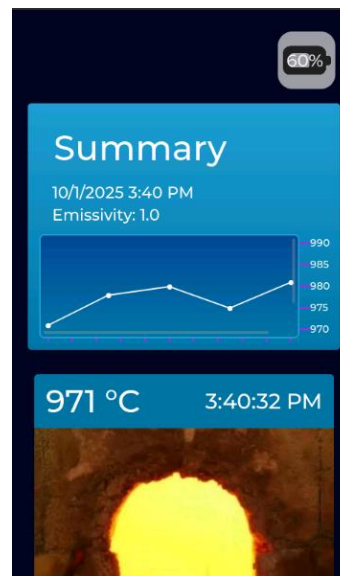



Figure 10 – Datapoints Screen

5.7.3 Deleting records

To delete a record, tap the trash icon . Select the records you would like to delete. Confirm deletion when prompted.

Deleted data cannot be recovered

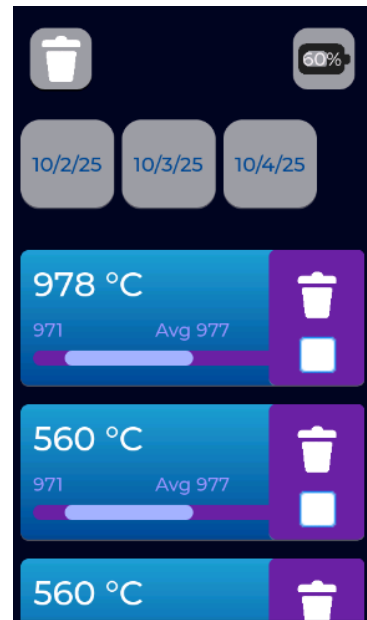

Figure 11 – Record Deletion Screen

5.7.4 Downloading Records

Measurement data and associated images can be downloaded directly from the device using a USB connection.

To download records:

1. Connect the device to a computer using a USB-C cable.
2. On the device, go to **Settings > Firmware Update**.
3. Tap **USB Connected** to enable file transfer mode.
4. A storage folder will appear on your computer.
5. Open the folder to access recorded measurement data and captured images.

Upon opening the folder 161045, you will find JPG file picture that was saved. The “trigger” was a text file with the captured data

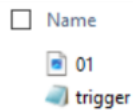

6. Copy or drag the files to your desired location on the computer.
7. Once complete, tap **USB Disconnected** on the device before unplugging the cable.

Note:

- File formats may include .csv for temperature data and .jpg for images, depending on configuration.
- HELIOS must have correct date entered and saved before pictures can start to record and before you will be able to connect via USB to your laptop
- When you first access HELIOS via USB on your laptop, DO NOT Encrypt the files if the option pops up.
- When you push “USB CONNECT” on HELIOS and choose DO NOT ENCRYPT, you will then see this under your File Explorer as a USB Drive D: as in below.

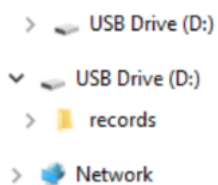

5.8 Settings

5.8.1 Setting Date / time

The Date / Time setting allows users to configure the current system clock.

Click on **Date / Time** from the Setting menu. Use the scroll wheels to select:

- Year, month, and day (YYYY/MM/DD format)
- Hour and minute
- AM/PM selection

Press **Save** to apply the changes.

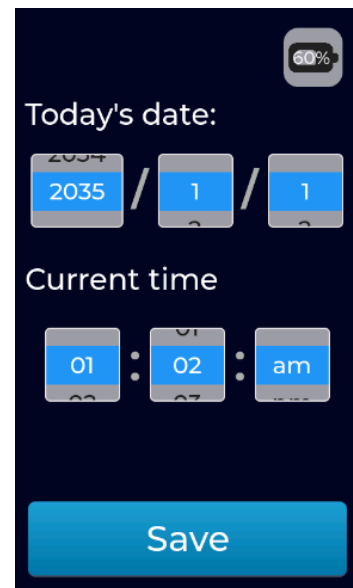

5.8.2 Updating firmware

Firmware updates provide new features, improvements, and bug fixes. To update the EXACTUS® HELIOS, follow the steps below:

Step 1: Download the firmware file

1. Visit the official BASF Temperature Sensing website: [Temperature Sensors | BASF Catalysts \(placeholder\)](#)
2. Navigate to the **EXACTUS® HELIOS** section under **Firmware Downloads**
3. Download the latest firmware update file to your computer

Step 2: Transfer and apply the update

1. Connect the device to your computer using a USB-C cable
2. On the device, go to **Settings**  > **Connect PC**
3. Tap **USB Connected** to enable file transfer
4. A storage folder will appear on your computer. Copy or drag the firmware file into this folder. Note: Firmware file is named “*issa_firmware.bin*”

 *issa_firmware*

BIN File

5. Once the transfer is complete, tap **USB Disconnected**
6. Press **Reboot** to install the update

Note: Make sure to download the latest firmware version. Do not install a version that is the same as or older than your current firmware.

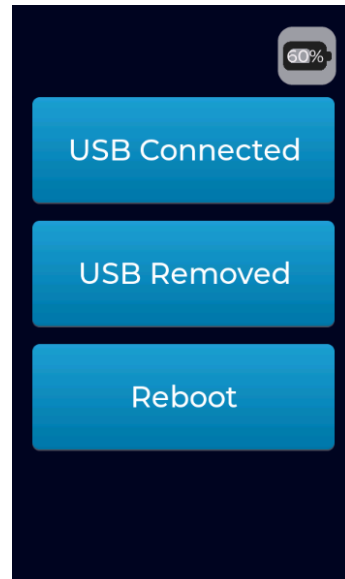

5.8.3 Setting Temperature Units

To change the temperature display units:

1. From the Settings Menu , tap **Temperature Units**.
2. Select either **Celsius (°C)** or **Fahrenheit (°F)**.
3. The selection will be applied immediately.

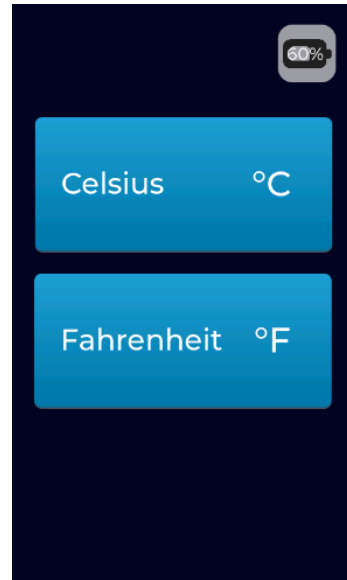

5.8.4 Brightness and Laser Control

This device provides controls for both the screen brightness and the laser settings.

Screen Brightness:

- Adjust the circular slider to set the desired brightness level for the display.

Laser Settings:

- Use the toggle switch to turn the laser **on** or **off**.
- Adjust the horizontal slider to set the **laser brightness level**.
- Both controls apply to the dual green targeting lasers.

Tap **Save** to apply all changes.

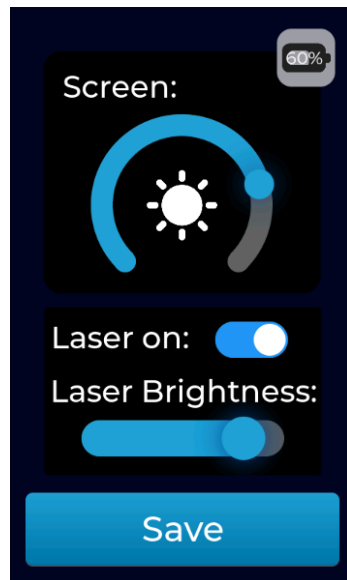

5.8.5 Power Management Settings

This device allows the user to configure power-saving behavior:

- **Dim screen after:** Sets the number of seconds before the screen dims and the unit in sleep mode. Touching the screen or pulling the trigger will turn the screen back on.
- **Shut down after:** Sets the number of minutes before the device powers off.
- Press **Save** to apply changes.

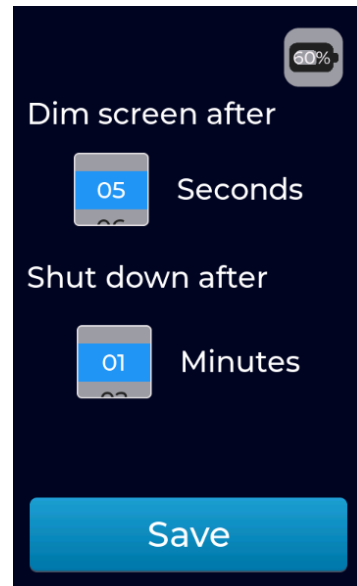

5.8.6 Format and Factory Reset

This device allows users to either erase stored data or restore factory default settings.

Format USB Drive:

- Erases all saved measurements and images stored on the internal storage.
- A confirmation screen will appear before proceeding.
- This action cannot be undone.

Factory Reset:

- Resets all device settings to factory defaults, including emissivity, units, brightness, timers, etc.
- Stored measurement data is not affected.
- Use with caution, typically only in troubleshooting or setup scenarios.



5.8.7 Device Information

The Device Information screen displays version details for hardware and firmware. This includes:

- Model number
- Installed firmware version
- Date of last calibration

This information may be required for support or maintenance requests.



6 Replacing the battery

The battery used by the EACTUS HELIOS is a commonly available Li-ion pack. It can be accessed through the battery cover on the handle grip. After removing the 4x M2 screws the battery can be removed and replaced. Caution should be observed that the battery connector is replaced into the connector pocket and inserted without compression between the battery and the case.

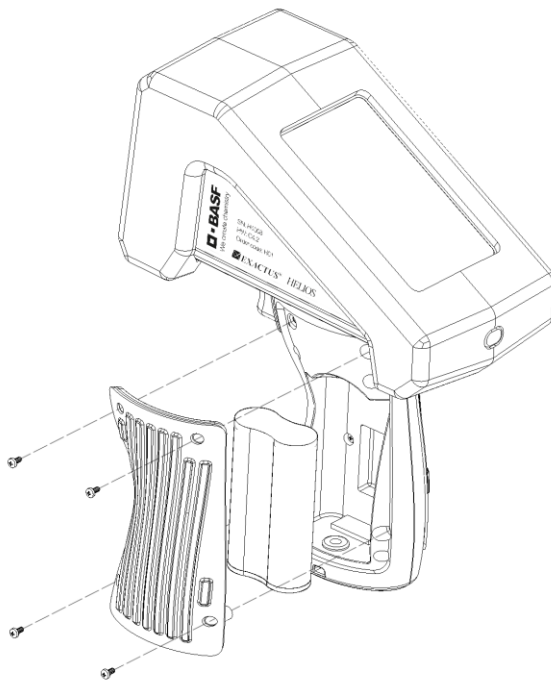

7 Troubleshooting

(Placeholder for future user feedback)

8 Warnings

Failure to follow the instructions and specifications contained in this user manual may result in impaired device function.

Device temperatures above or below the recommended operating range will affect temperature measurement accuracy. Temperatures exceeding 60°C may result in device shutdown. Use radiation shielding air where appropriate to keep the device within operational limits.

8.1 Repair, Service, and Returns

Repairs may only be carried out by BASF or BASF authorized agent; this device contains no user serviceable parts. Devices returned to BASF must be shipped in protective packaging. Use the Contacts listed in Section 0 for further instructions and to obtain an RMA number.

8.2 Disposal

This device contains electronic components and in the event of disposal must be treated as electronic waste. Consult your local regulations before disposal.